

ESD BASICS



BASIC CONCEPTS IN ELECTROSTATIC DISCHARGE (ESD)



Introduction



ESD Control Training



All Materials Tribocharge



ElectroStatic Charge Generation:

- When 2 Surfaces in Contact then Separate
- Some Atom Electrons Move Causing Imbalance

One Surface Has Positive Charge & One Surface Has Negative Charge

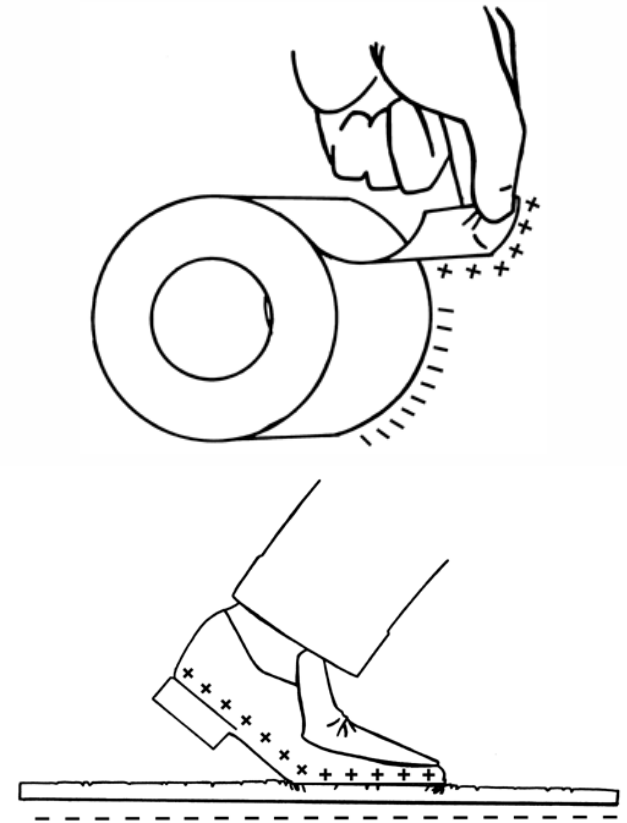

Examples Of Electrostatic Discharge or ESD

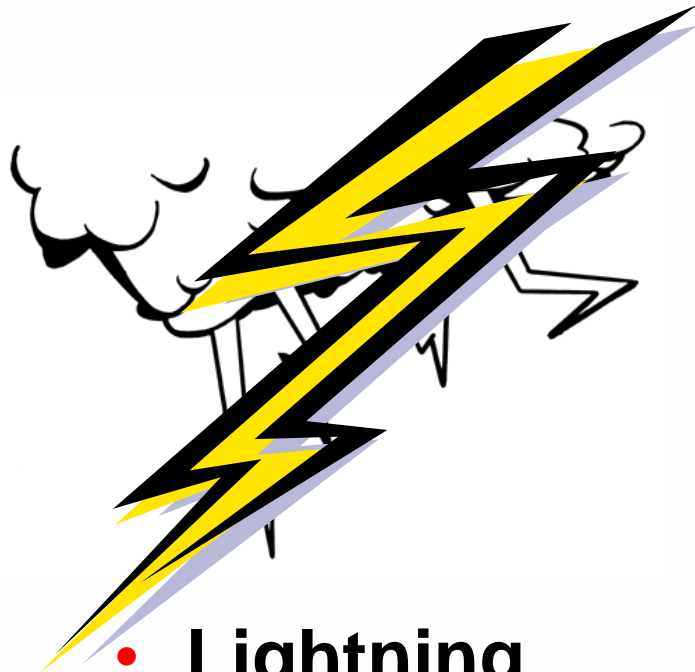

- **Lightning**

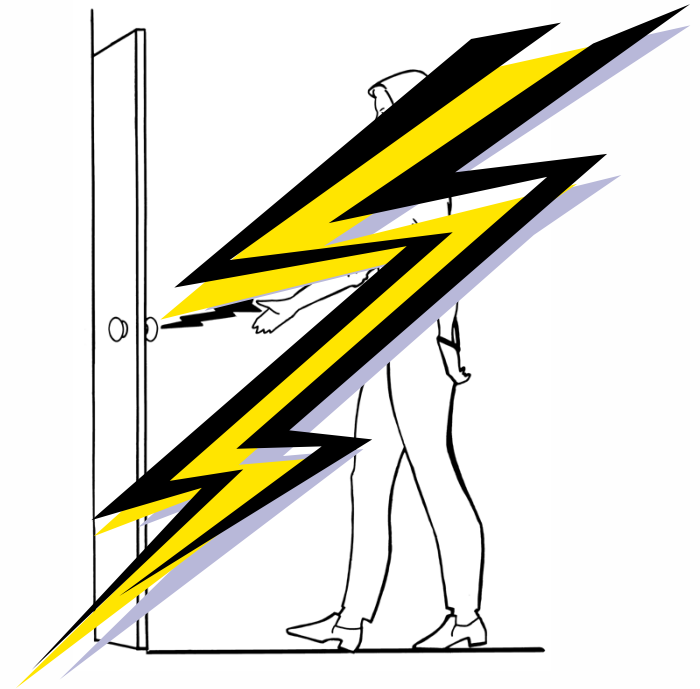

- **Zap from a door**



ESD or ElectroStatic Discharge



- Charges Seek Balance
- Discharge is Rapid
- Creating Heat

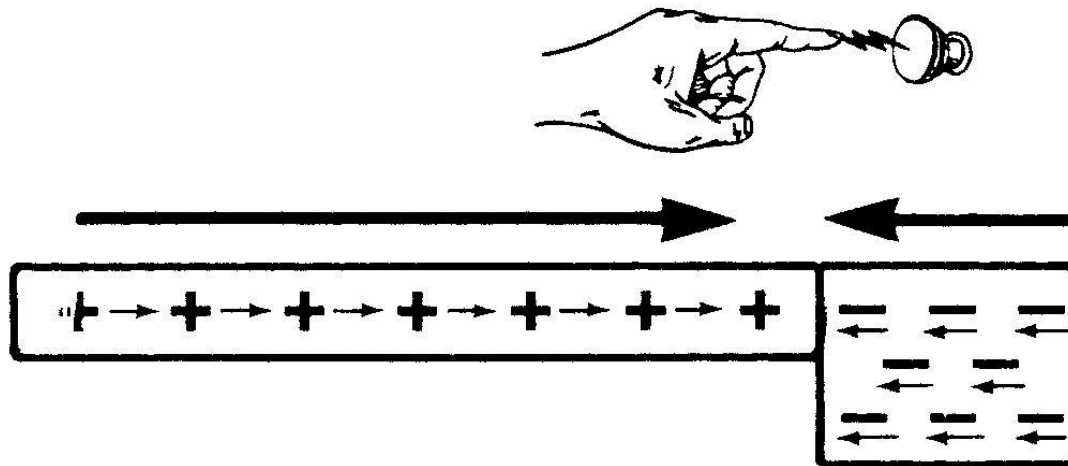

Two Types of Materials Conductors



- Electrical Current Flows Easily
- So Can be Grounded
- Can Discharge
- Examples Metals and People

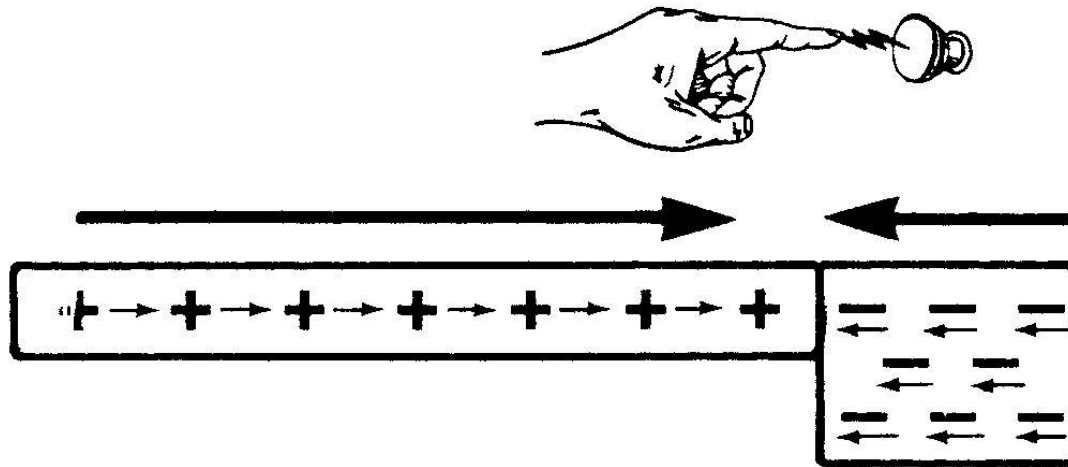

Two Types of Materials Insulators



- Electrical Current Does Not Flow Easily
 - Cannot be Grounded
 - Example: **Plastics**
- Typically very high charging

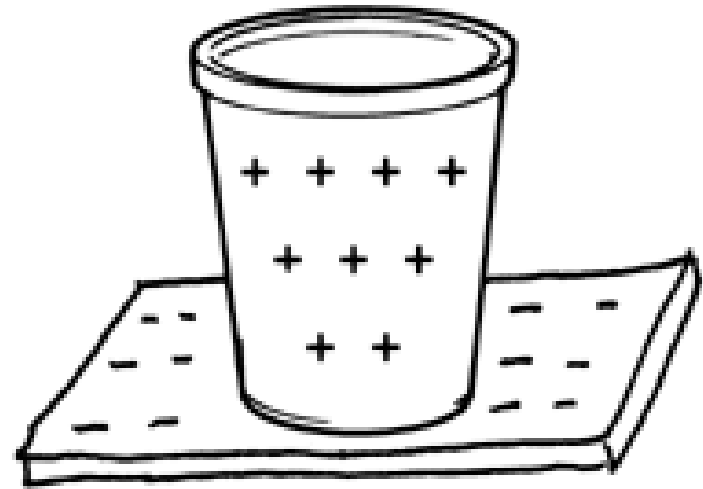

Large Charges Generated All The Time



- Walking across a carpet:
1,500 - 35,000 volts
- Walking over untreated vinyl floor:
250 - 12,000 volts
- Vinyl envelope used for work instructions: **600 - 7,000 volts**
- Worker at a bench:
700 - 6,000 volts
- Unwinding regular tape:
9,000 - 15,000 volts

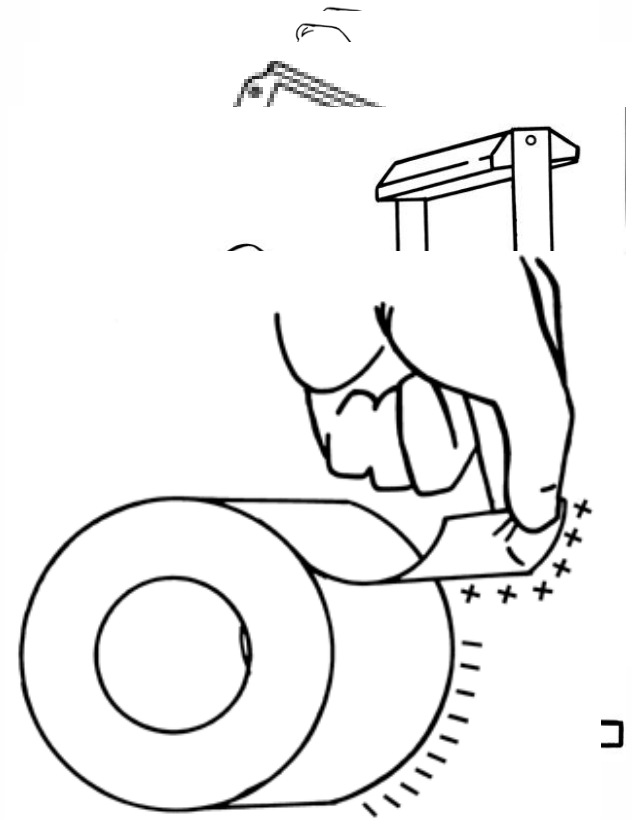

People Discharge Frequently



**But To feel a
Discharge it
must be
about
3,000 volts**

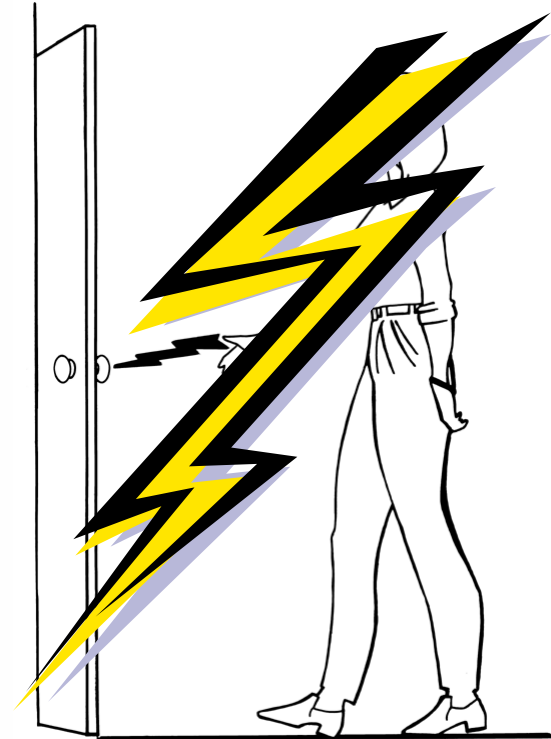

ESD That A Person Can't Feel Can Easily Damage Electronic Components



**100 volts or
less can
damage
components!**

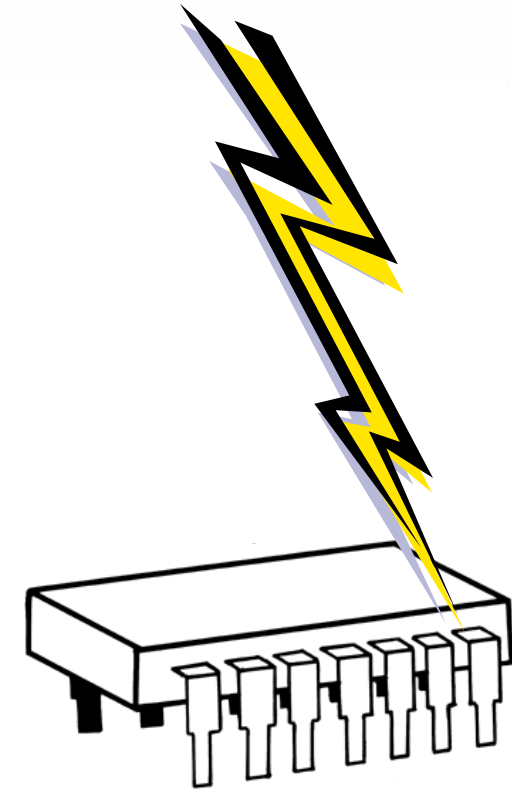

Electronic Component ESD Sensitivity (ESDS)



Human Body Model (HBM)

- ESD Class 0: Damage you can't feel: **0 to 199 Volts**
- ESD Class 1: Damage you can't feel: **200 to 1,999 Volts**
- ESD Class 2: Damage you might feel: **2,000 to 3,999 Volts**
- ESD Class 3: Damage you can probably detect as spark with your own body: **4,000 to 15,999 Volts**



Tiny Conductive Paths Can Easily Be Damaged



Smaller components mean greater sensitivity to ESD. Damage to these components can not be detected by the naked eye.

- At this magnification we see that 1/2 of the width of the material has been destroyed

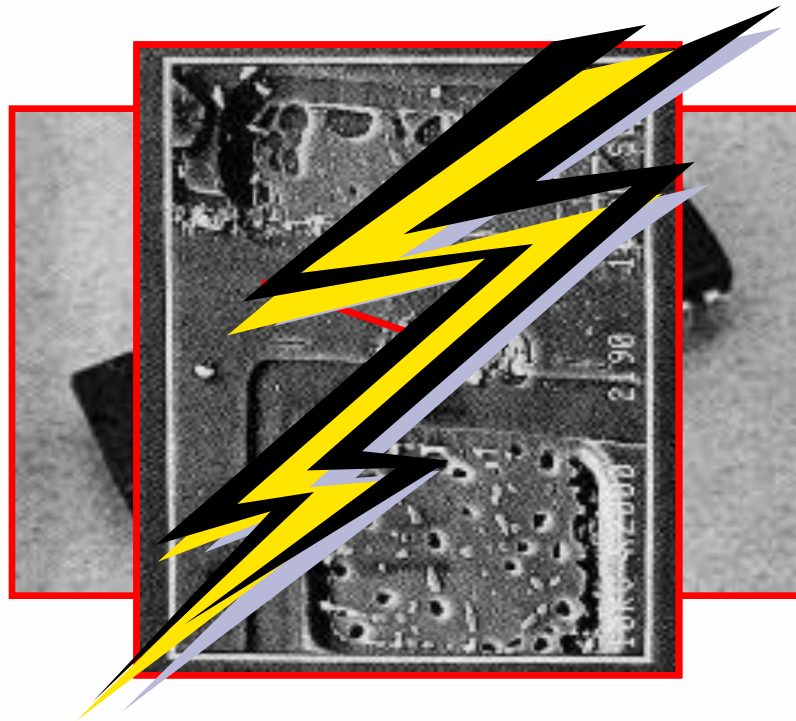

At higher magnification, the pit in the area between the base and emitter becomes more obvious

- Integrated Circuit



Types Of ESD Device Damage



- **Latent Defect**
Component wounded
But Inspection Passes
- **Catastrophic Failures**
Inspection
Able to detect

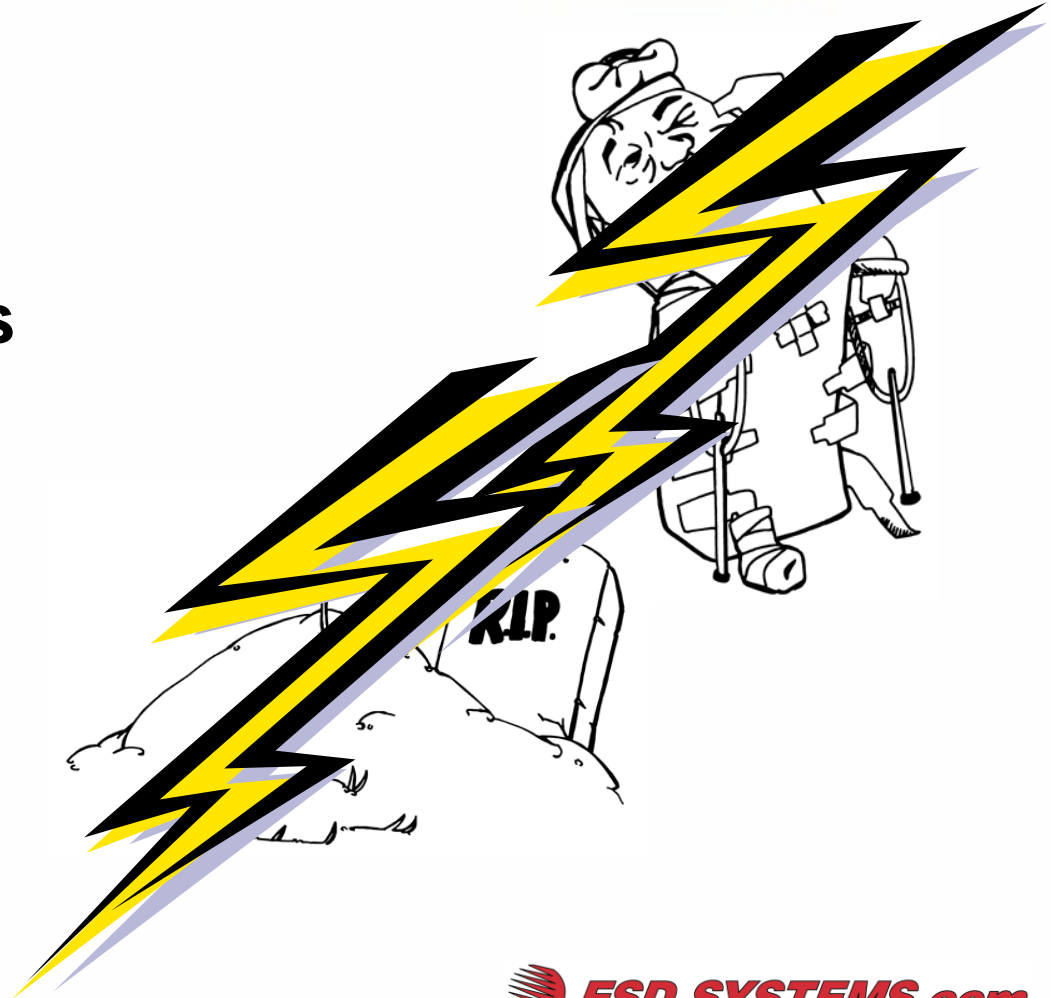

Latent Defects More Costly

- Sub Assembly passes inspection
- Assembly passes inspection
- Product passes inspection
- Works a while for customer
- Then Upsets & Mysterious Problems
- More Returns
- More Warranty Costs
- Lower Customer Satisfaction

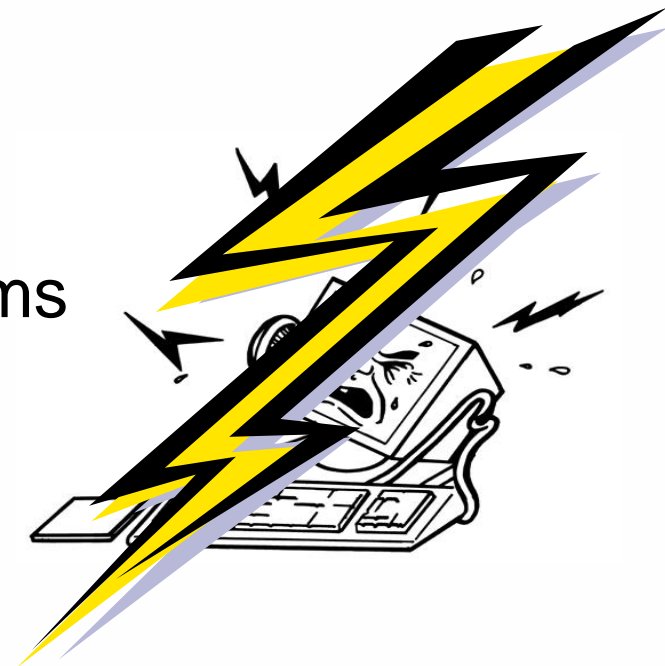

Like Germs, ESD Is The Hidden Enemy



Control Germs

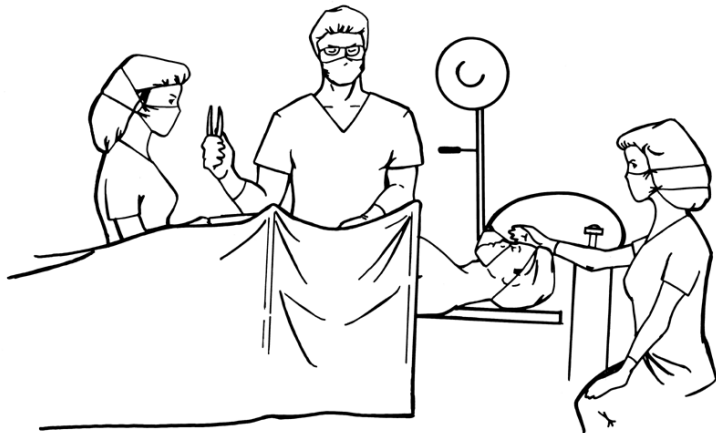

We are aware of sterilization in medicine

Control ESD

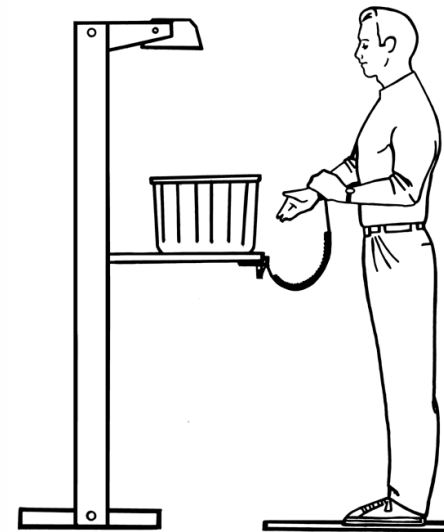

We should develop the same attitude about ESD

 **ESD SYSTEMS.com**

www.esdsystems.com



The Prerequisites of ESD Control



- Identify ESD Area
- Identify ESD sensitive items
- Provide ESD control training



The Basics Of ESD Control



- Ground Conductors
- Shield ESDS
When store
or transport
outside EPA
- Neutralize
insulators
with ionizers



Ground Conductors Including People



- Wrist Straps
- Must work, so test wrist strap daily
- Foot Grounders
- Must work, so test foot grounder daily



Ground All Conductors in ESD Protected Area

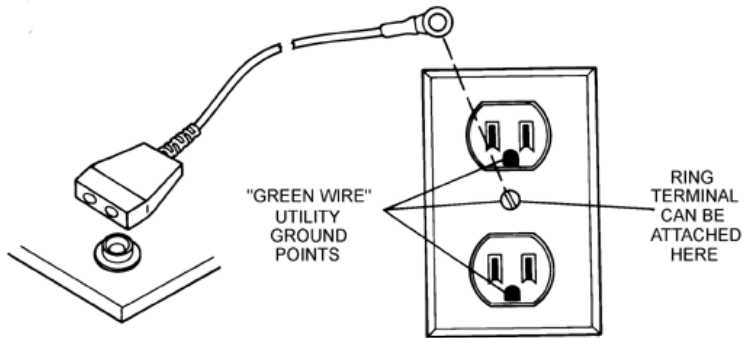

- **Dissipative WorkSurfaces**
 - Ground ESD worksurface via ground cord to common point ground to equipment ground

- **Conductive Floor Mats**

- Ground ESD floor mats via ground cord to equipment ground

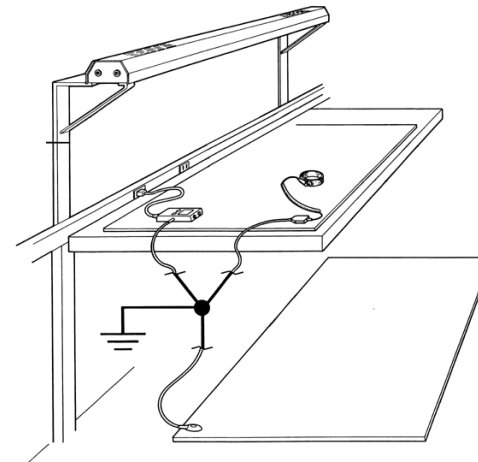

Neutralize Insulators Via Ionizers



- Charged Insulators Cannot be grounded
- Ionizer air flow floods area with Ions
- Neutralizing Charge

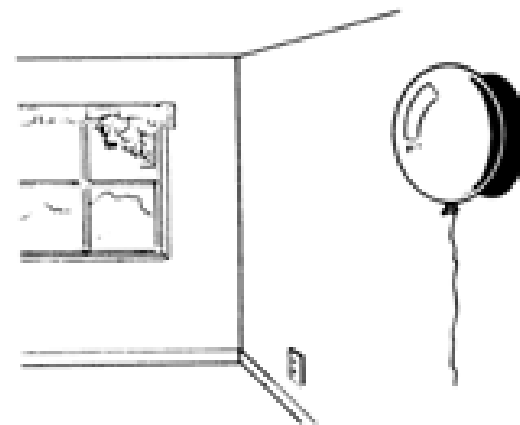
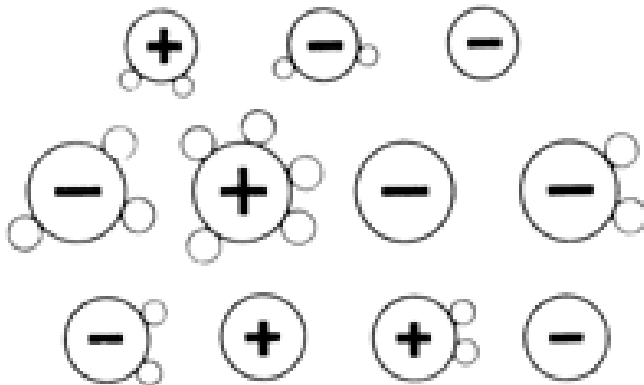

Shield ESD Sensitive Items Outside Protected Area



Faraday Cage

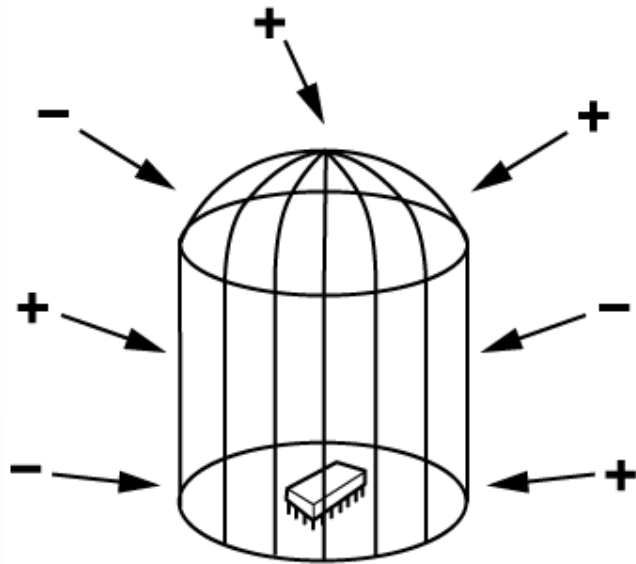

Charges Kept on Outside of Package:

- Closed Metallized Shielding Bag
- Covered conductive tote box

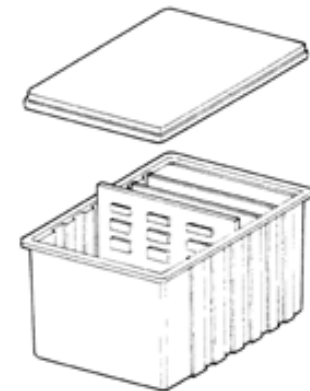

ESD Protected Products

Regular Versions changed to be Low Charging and/or Groundable



Remove Insulator or Change to ESD Version

- ESD Smocks and Gloves
- Conductive Foam & Shunt Bars
- Antistatic or Low Charging Tape
- Dissipative Binders & Document Protectors
- Dissipative Floor Finishes
- Conductive & Dissipative Flooring



You Are On The Front Lines Fighting The Hidden Enemy



- Test Wrist Straps & ESD Footwear daily
- Keep wrist band snug, foot grounder grounding tab in shoe, & ESD Smocks buttoned up
- Only trained or escorted people allowed in ESD Protected Area



You Are On The Front Lines Fighting The Hidden Enemy



- Keep work area clean & clear of insulators
- Handle un-packaged ESD sensitive items only when grounded
- Visually check all grounding cords to make sure they are connected



You Are On The Front Lines Fighting The Hidden Enemy



- Make sure Ionizers are maintained and air flow is not blocked
- Use shielded packaging for shipping or storing ESD sensitive items outside the ESD Protected Area



The Basics Of ESD Control



- Ground Conductors including people
- Neutralize insulators with ionizers
- Shield ESDS when store or transport outside EPA



ESD BASICS



BASIC CONCEPTS IN ELECTROSTATIC DISCHARGE (ESD)

